

Elevation 1:25

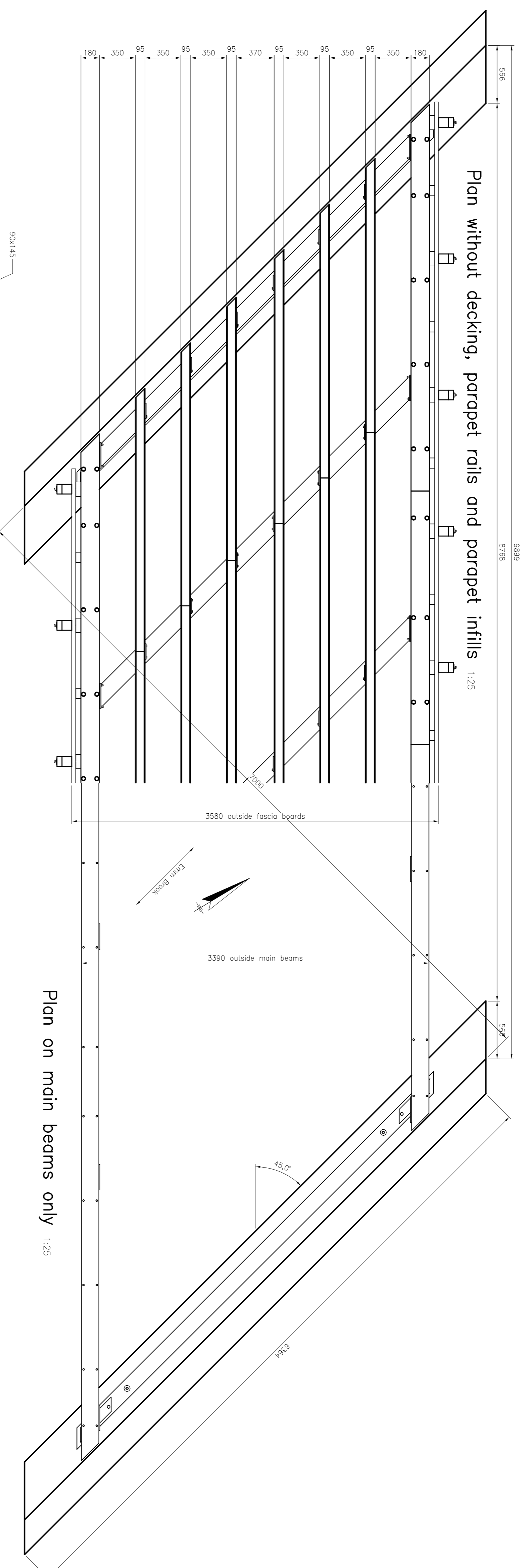

Plan on main beams only 1:25

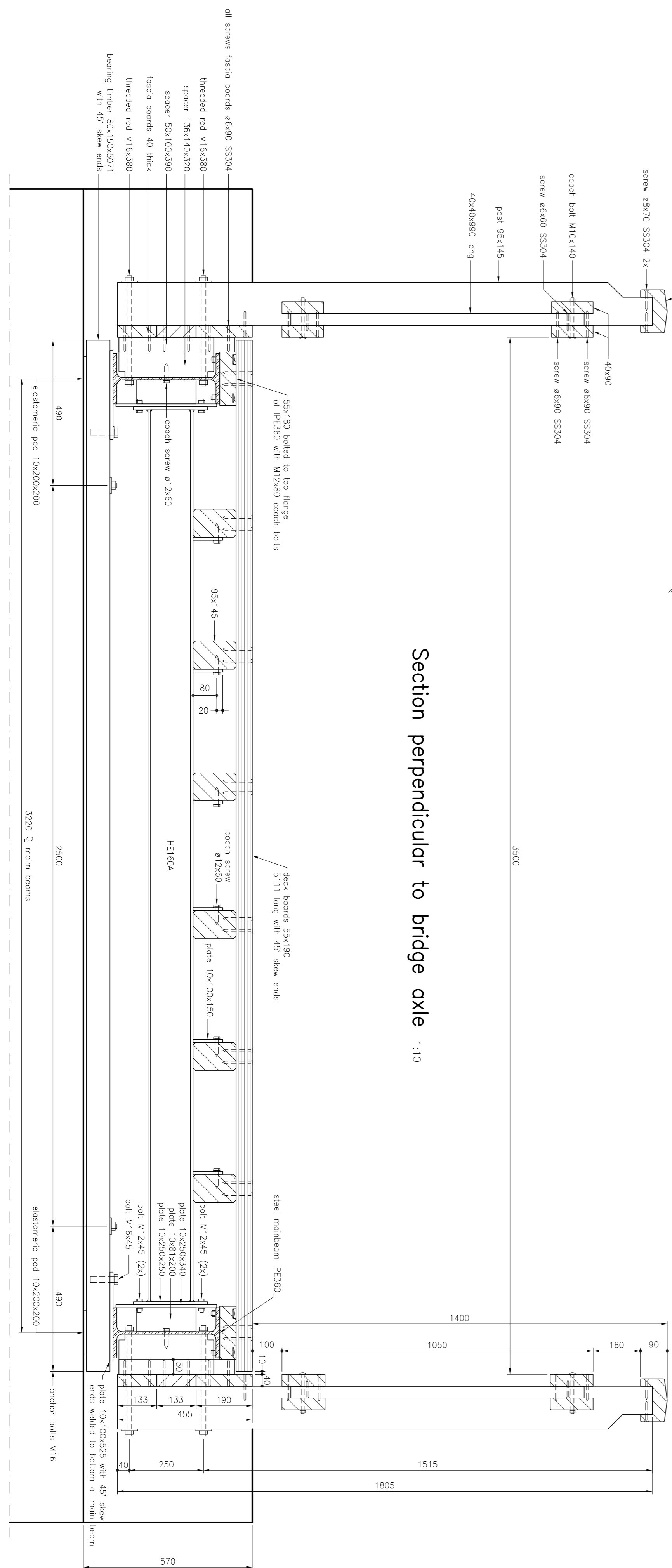

Section perpendicular to bridge axle 1:10

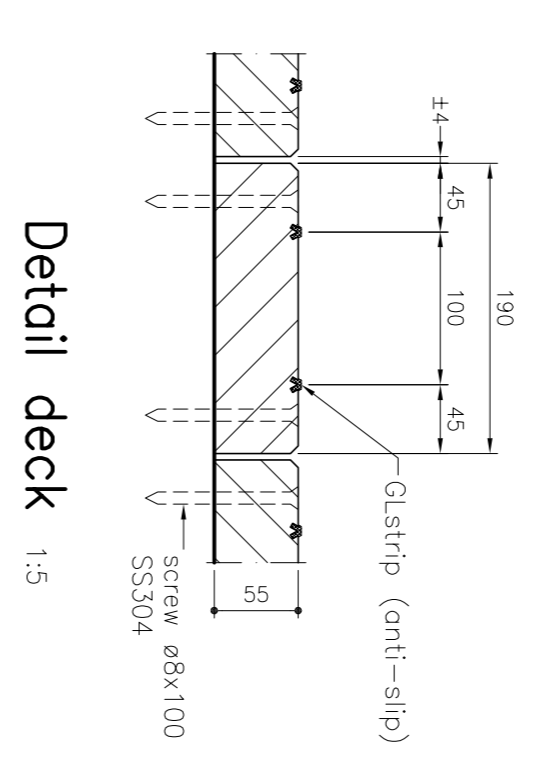

Detail deck 1:5

### Safety, Health and environmental information

In addition to the hazards/risk normally associated with the types of work detailed on the drawing, please note the following:

- Construction**  
-No risks during construction have been identified that could not reasonably have been foreseen by a competent contractor.  
(It is assumed that all works will be carried out by a competent Contractor working, where appropriate, to an agreed method statement)

**Residual Risks:**  
None

**Class:** Pedestrians  
**Load:** 5 kN/m<sup>2</sup> and vehicles up to 5 tons  
**Vehicle with 2 axles spaced at 3.0m**  
**Front and rear axle 25kN**  
**Maximum wheel load 12.5kN acting on a square surface of sides 250mm**  
**Wheel distance 1.7m**  
Provisions are to be made to limit access of vehicles weighing over 5 tons

**Timber:** EKI FSC 100% NC-COC-005535 AV  
**Steelparts:** S235 galvanised, unless mentioned otherwise  
**Fittings:** Grade 8.8, unless mentioned otherwise

Sizes in mm, unless mentioned otherwise  
Levels are in metres

No.	Date Issue	Design	Drawn	Checked	Description/revision/description

<b>Project:</b>		<b>Date approved:</b>	
<b>South East Rivers Trust</b>		24-06-2022	
<b>Leatherhead, Surrey</b>		<b>Date issued:</b>	
<b>Name structure:</b>		24-06-2022	
<b>Emm Brook Restoration, Fish Passage Improvements</b>		<b>Design:</b>	
<b>Woosehill, Wokingham</b>		KW	
<b>Name structure:</b>		<b>Drawn:</b>	
<b>Emm Brook Restoration, Fish Passage Improvements</b>		KW	
<b>Woosehill, Wokingham</b>		<b>Checked:</b>	
<b>Part structure:</b>		as shown/A1	
<b>Installation of two bridges, Bridge A: Southern Bridge.</b>		<b>Drawn by - part:</b>	
<b>General Arrangement with details</b>		E5741-20190234-02	
<b>SARUM HARDWOOD STRUCTURES LTD</b>		<b>Scale:</b>	
<b>INC. MAT &amp; TIMBER SERVICES</b>		as shown/A1	
Unit 15, Chilton Down Farm		<b>Drawn by - part:</b>	
Stockbridge, Hampshire, SO20 8BU		191795	
Tel: 01256 312840		<b>Sheet:</b>	
info@sarumhardwood.co.uk		PREFAZ® Type 2s	
www.sarumhardwood.co.uk		FSC	
www.fsc.org		www.fsc.org	

This document contains information proprietary to GROUPT LEMMER B.V. Any disclosure or use of the proprietary information or reproduction of this document is expressly prohibited except as GROUPT LEMMER B.V. may otherwise agree in writing.

This page is intentionally left blank